

ETHERNET ATTACHED TFT PROJECT

POWER SUPPLY MODULE

SCHEMATIC DIAGRAMS

REVISION 0.1
SEPTEMBER 2006

- Revision history2
- Block diagram3
- Detailed schematics4
 - Power input4
 - 3.3V/5V dual power supply4
 - 1.2V power supply5
 - 2.5V power supply5
 - Output connector5

Revision history

0.1 (2006-09-01)

- Initial revision

Block diagram

The power supply is composed of several separate power supplies. While the first one is a dual output switched mode power supply (SMPS) with MAX1634, the two lower voltage stages are powered from 5V and use the MAX1714B controller.

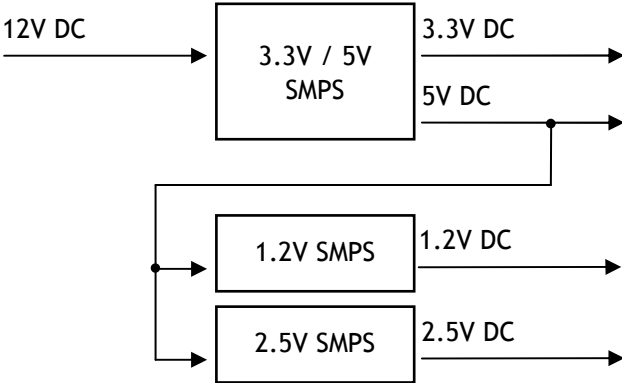

Fig.1: Block diagram of the power supply

Detailed schematics

Power input

The input connectors are PC-style power connectors. Both 3.5" and 5.25" power connectors are supported. The power supply itself uses only the 12V branch.

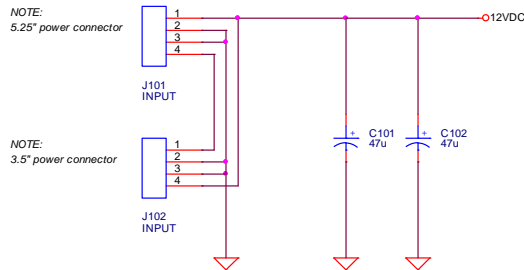

Fig.2: Input connectors

3.3V/5V dual power supply

The 5V output is not used by the target device, so it is safe to use it for powering the low voltage supplies (1.2V and 2.5V).

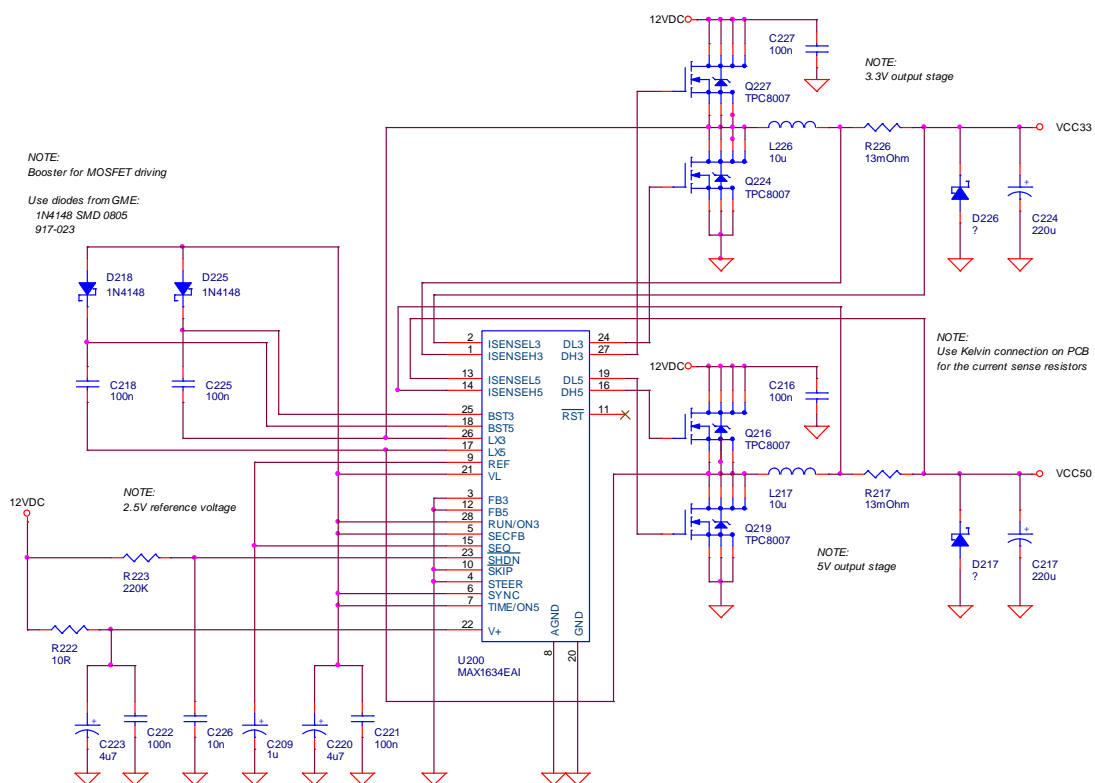

Fig.3: The 3.3V and 5V switched mode dual power supply

1.2V power supply

Uses a MAX1714B controller which is configured with two external resistors for 1.2V.

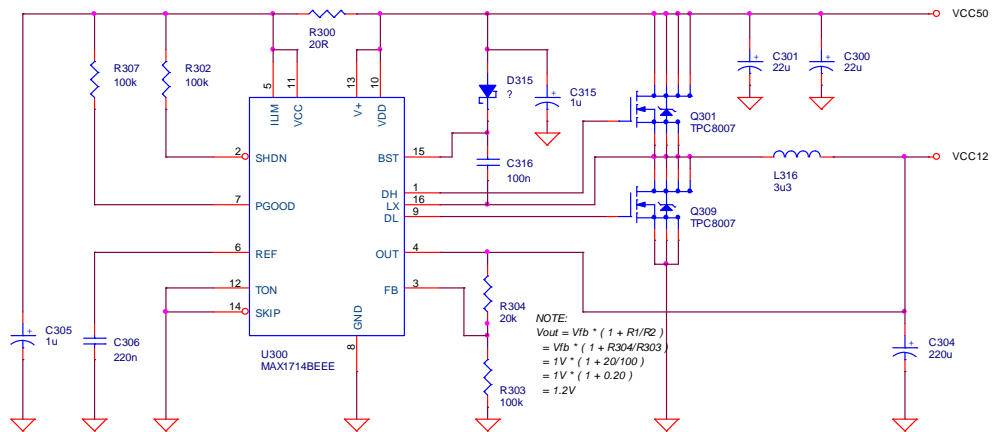

Fig.4: The 1.2V switched mode power supply

2.5V power supply

Uses a MAX1714B controller which is configured internally for 2.5V (FB grounded).

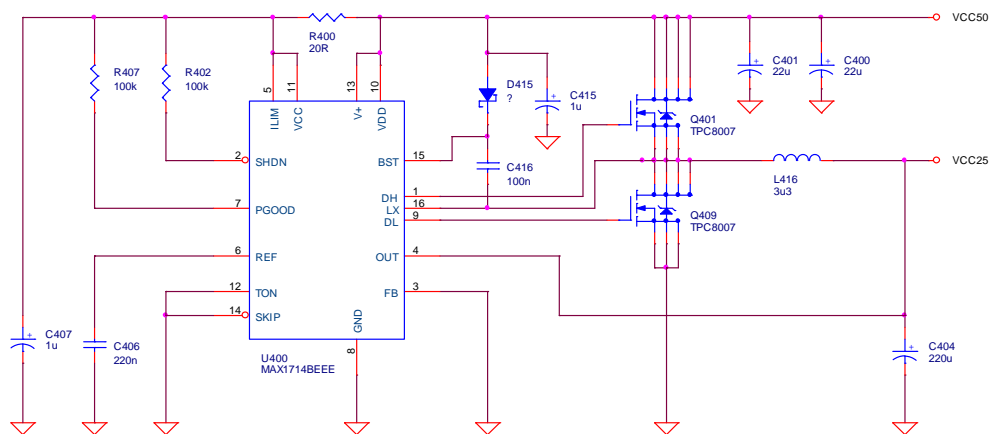

Fig.5: The 2.5V switched mode power supply

Output connector

The connector matches the pinout used by the display controller.

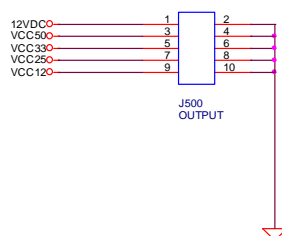

Fig.6: The output connector